

# High Resolution Compact Rotation Stages

SR50 Series

**mks** | Newport

The SR50 compact rotation stages are designed to rotate optical components up to 1 in. diameter, such as polarizers, wave plates, or wedges. The small size provided by the folded motor design allows use in confined spaces, such as laser cavities, disk texturing machines, or manufacturing areas for fiber optical components.

The SR50 stages feature minimum incremental motion of  $0.004^\circ$ , which may be achieved with either DC Servo or open-loop stepper motors (half-step mode). The stages are equipped with a hardware origin allowing the stage to return to a reference home position to within  $0.01^\circ$ . SR50 stages can run in continuous rotation mode.



- Compact, low-profile rotation stage for 1 in. diameter optics
- Lightweight, folded motor design
- Proprietary ball bearings for smooth motion with low wobble
- High resolution

## Vertical Mounting

The optional EQ45 bracket can be used for vertical mounting of a SR50.

## CONEX Controller Versions

Versions of these stages integrated with a CONEX controller are also offered. The CONEX controller comes with a USB cable and a CONEX-PS-CB to allow daisy-chaining modules. Conex-PS power supply to be ordered separately.

## Proprietary Ball Bearing Design

The lightweight, low profile design incorporates an aluminum body with pre-loaded ball bearings. This proprietary ball bearing design provides smooth rotation with minimal wobble. A precision ground worm gear produces consistent driving torque to the rotating carriage and eliminates variations in motor current.

## Central Aperture

The central aperture is threaded 1.063-20 in. SR50 stages are shipped with two, same diameter retaining rings to allow mounting of any  $\varnothing 25.4$  mm diameter optics within the aperture. Four M3 holes allow custom top plates attachments.

## Folded Motor Design

The motor is folded inside the stage body to give an extremely small footprint for a stage at this level of precision.

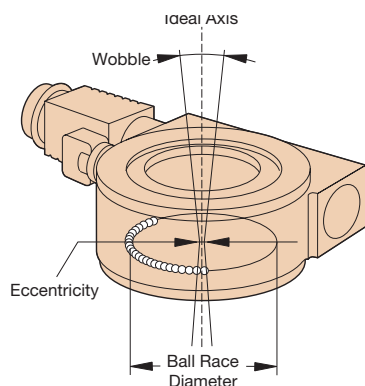
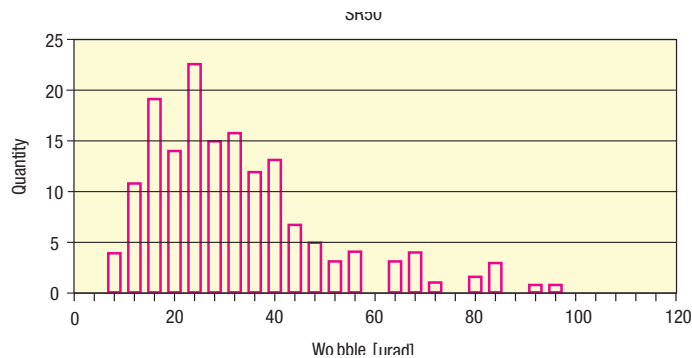
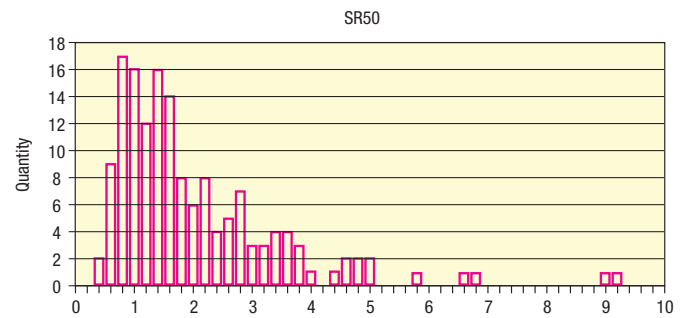
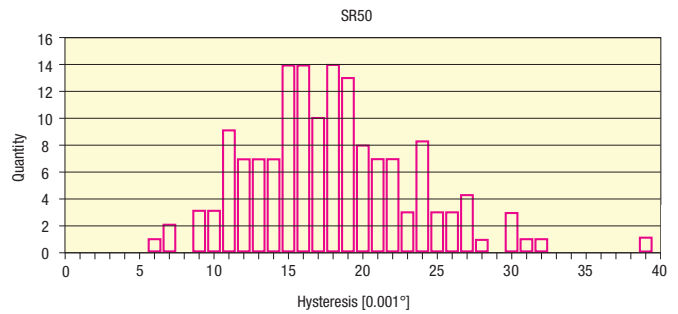

## Specifications

	SR50CC	SR50PP
Travel Range (°)	380 continuous	
Minimum Incremental Motion (°)	0.004	
Uni-directional Repeatability, Typical/Guaranteed (°)	$\pm 0.0025/\pm 0.005$	$\pm 0.0035/\pm 0.005$
Bi-directional Repeatability, Typical/Guaranteed <sup>(1)</sup> (°)	$\pm 0.015/\pm 0.025$	$\pm 0.016/\pm 0.025$
Accuracy, Typical / Guaranteed <sup>(1)</sup> (°)	$+0.015 / \pm 0.03 \pm$	$\pm 0.020 / \pm 0.030$
Maximum Speed <sup>(2)</sup> (°/s)	4	1.6
Wobble <sup>(1)</sup> Typical/Guaranteed (µrad)	$\pm 20 / \pm 50$	
MTBF (h)	10,000	
Weight (kg)	0.3	

<sup>1)</sup> For the definition of Typical and Guaranteed specifications see "Motion Basics Terminology & Standards" Tutorial at [www.newport.com](http://www.newport.com)

## Load Characteristics

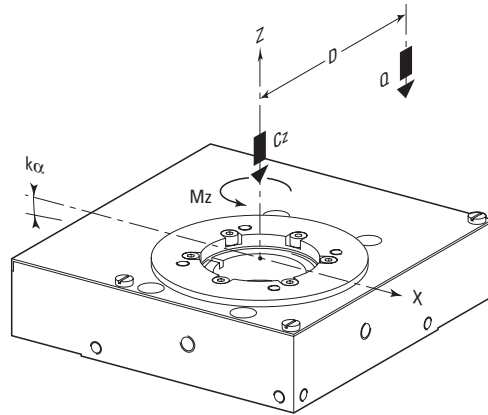

		SR50CC	SR50PP
$C_z$ ,	Normal centered load capacity		30 N
$K_\alpha$ ,	Transversal compliance		160 $\mu\text{rad}/\text{Nm}$
$M_z$ ,	Nominal torque	$\pm 0.4 \text{ Nm}$	$\pm 0.5 \text{ Nm}$
$Q$ ,	Off-center load (N)	$Q \leq C_z \div (1 + D/25)$	
	Where D = Cantilever distance (mm)		

## Dimensional Drawings

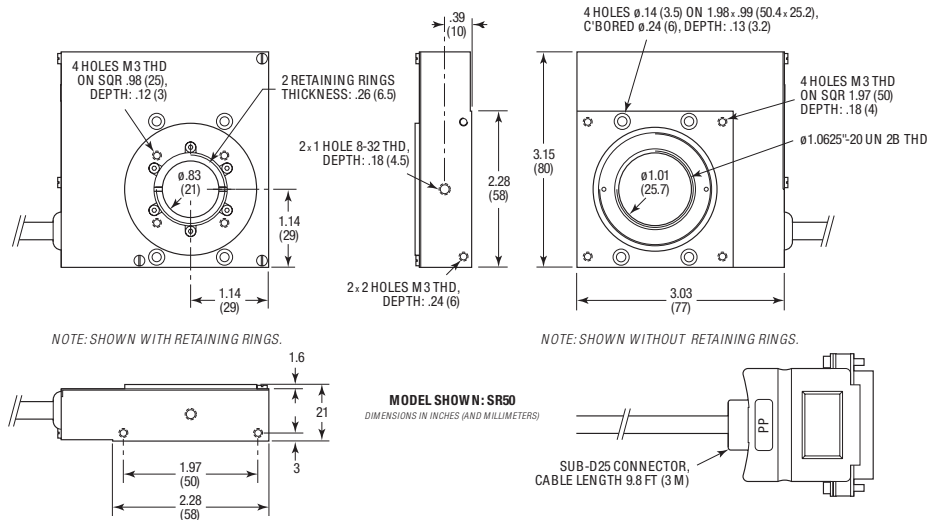

## Accessories

Model	Description
EQ45	Compact Rotation Stage, 360°, DC Servo Motor, PR Series

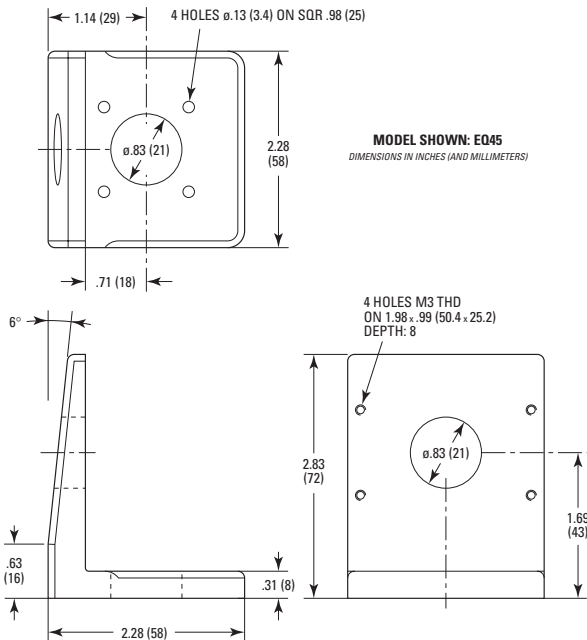

## Recommended Controllers/Drivers

Model	Description
XPS-Dx	1- to 8-axis universal high-performance motion controller/driver
XPS-DRV11	Universal digital driver card for stepper, DC and direct motors (required for SR50PP)
XPS-DRV01*	PWM Drive Module, DC and Stepper Motors (required for SR50CC)
XPS-RLDx	1- to 4-axis universal high-performance motion controller/driver
ESP302-xN	1- to 3-axis motion controller/driver
SMC100CC	Single-axis DC motor controller/driver
SMC100PP	Single-axis stepper motor controller/driver

\* Plug XPS-DRV01 into slots other than slot 1.

## Ordering Information

Model	Description
SR50CC	Compact Rotation Stage, 360°, DC Servo Motor, SR Series
SR50PP	Compact Rotation Stage, 360°, Micro Step Drive Stepper, SR Series
Conex-SR50CC	SR50CC, Integrated with Conex Controller
Conex-PS	Power supply, Conex